

# **Series LP-3000**

**Land-O-Matic™ Dry Pellet Chlorinator**

---

***Installation, Operation and Maintenance Manual***

---

# Installation and Operation Instructions

## Congratulations

You are now the owner of the most dependable device available today for the automatic chlorination of well water. The LAND-O-MATIC feeds dry chlorine pellets at an adjustable rate directly into the well casing or other water vessel. It is designed to dispense dry chlorine pellets simultaneously with the operation of a water pump. The use of dry chlorine eliminates many of the maintenance and service problems commonly associated with liquid chlorination systems.

When properly installed and operated according to the instructions in this manual, your LAND-O-MATIC will provide years of satisfactory trouble-free service, with minimal maintenance, for the control and treatment of:

- Nuisance bacteria
- Spread of waterborne diseases in livestock watering systems
- Growth of iron bacteria in wells, pumps, and water systems
- Hydrogen sulfide gas and odor
- Algae, scum, slime and fungus growth
- Tastes and odors of organic origin

**Note:** The LAND-O-MATIC system oxidizes and precipitates iron and manganese as the first step in complete removal. A carbon, sand or iron filter is required to remove precipitated contaminants from the chlorinated water. These filters may also remove the chlorine residual.

## I. Mount the Chlorinator

The LAND-O-MATIC must be rigidly mounted at the correct angle for proper operation. Improper mounting will result in the jamming of chlorine pellets. The installed LAND-O-MATIC must be rigid enough to resist movement due to wind, accidental bumps and servicing.

- Install the casing mount on the well (Figure 1):
  - Position the bracket (#2) 1/2 inch below the bottom of the well cap and attach the bracket to the well casing using the two chains (#4), four J-bolts (#5), four flat washers (#6) and four hex nuts.
  - Attach the support tube (#7) to the bracket using two clamps (#1) and four bolts (#3).  
**Important:** The support tube must be installed with the chlorinator label end up.
  - Attach the chlorinator mounting bracket to the chlorinator (Figure 3) and install the chlorinator onto the support tube.

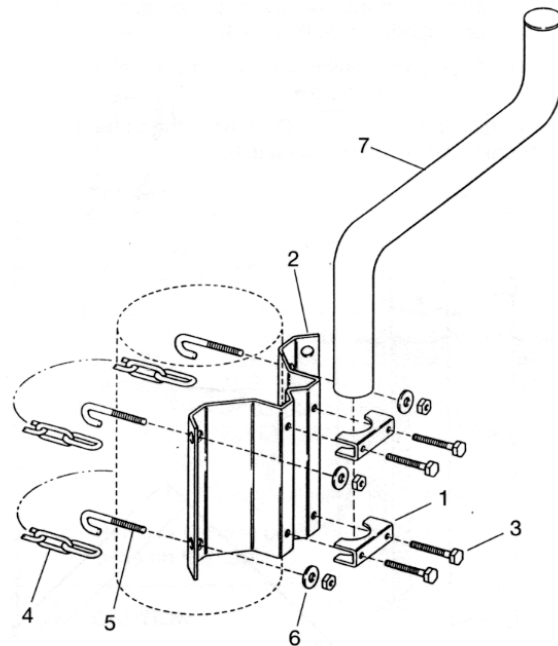

Figure 1

Table-1 Series LP-3000 Specifications

	Model LP-3015	LP-3115	Chlorine Pellets
Electrical Rating	115V, 60/50 Hz	220V, 60/50 Hz	EPA registered 50510-1
Power Requirement	26 watts	31 watts	Active Ingredient: Calcium Hypochlorite 70%
Fuse Protected	Yes	No	Inert ingredients, Soluble Material 30%
Pellet Feed Rate (Max.)	6 pellets/minute		Available Chlorine 70%
Pellet Storage (Max.)	15 pounds (6.8 kg)		Pellet Weight 1 gram (0.035 oz)
Shipping Dimensions	12 5 in. x 15 3 in. x 30 5 in 31.8 cm x 38.9 cm x 77.5 cm		Pellet Size: 3/8 in. dia. x 5/16 long (9.5 mm x 7.9 mm)
Shipping Weight	31 pounds (14.1 kg) NSF-61 Listed for potable water		NSF-60 Listed for potable water

B. Install a 1-1/4 inch (3.2 cm) pipe as a mounting pipe (furnished by customer):

1. Locate the pipe as shown in Figure 2.
2. Dig a 4 foot (1.3 m) deep, 6 inch (15 cm) to 10 inch (25 cm) diameter hole.
3. Cement the pipe into the ground. Be certain pipe is absolutely vertical. Allow the cement to set.

**Warning:** When digging around wells avoid striking well pumps electrical power supply wires. electrocution could result.

- C. Attach the mounting bracket to the chlorinator and mount the chlorinator on the support tube or mounting pipe (Figure 3).
- D. Position the chlorinator facing the well and tighten all fasteners.

For installation of the LAND-O-MATIC in the State of Wisconsin, USA, reference page 5.

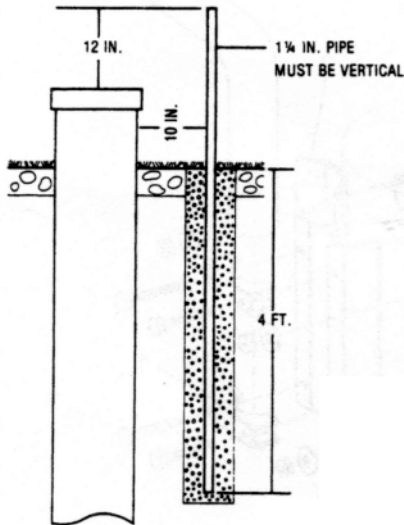

Figure 2

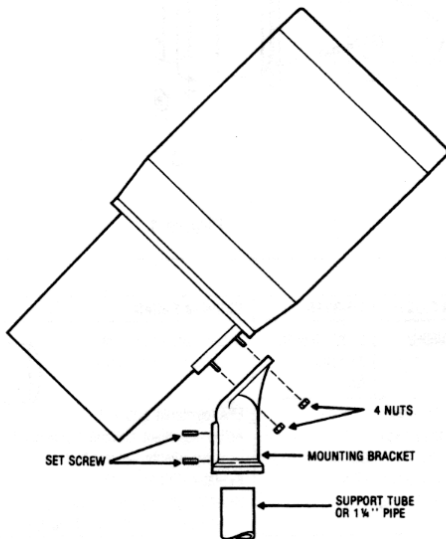

Figure 3

## II. Well Vent and Pellet Discharge Tube Installation Instructions

**IMPORTANT:** The chlorine pellets must fall freely from the chlorinator into the water in the well casing without interference from pitless adapters, cable guards, torque stops, excess electrical wire or related pump fittings. Chlorine pellets in contact with metal parts will cause severe corrosion.

**IMPORTANT: THE WELL MUST BE VENTED.** For the LAND-O-MATIC to function, the well must be vented to prevent moist air from the well from being forced up into the chlorinator pellet container, causing the pellets to soften and clog the pellet plate.

A. For wells with sealed or unsealed caps and pitless adapters:

Figure 4 illustrates a typical non-sealed well casing and the modifications required to assure that a) the pitless adapter does not prevent the pellets from dropping into the water: and b) adequate well venting is provided.

1. Turn off electrical power to the well pump system.
2. Remove the well cover.
3. Examine piping, wiring and pitless adapter. It may be necessary to lift the submersible pump in order to examine the pitless adapter. Determine the length of the pellet discharge tube (3/4" CPVC tube) that will be needed to extend through or around the pitless adapter and/or plumbing. **DO NOT USE METAL OR SMALLER TUBING.** The end of the tube must be above the static water level. Be sure that any "torque stops" used on the submersible pump are installed below the lowest water level.

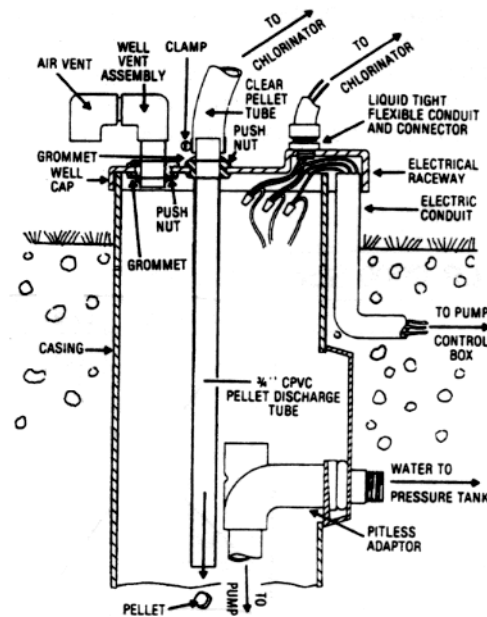

Figure 4

4. Drill a 1-1/4 inch (3.2 cm) diameter hole in the well cover corresponding to the location of the pellet discharge tube to be installed (Figure 4). Drill a second 1-1/4 inch (3.2 cm) diameter hole in the well cover for the well vent assembly shipped with the LAND-O-MATIC.
5. Drill a 23/32 inch (1.8 cm) diameter hole in the well raceway on the cover. Tap with a 1/2 inch pipe thread and install a liquid tight connector.
6. Remove the grommets and push nuts from the loose parts kit. Install the grommets in the 1-1/4 inch (3.2 cm) diameter holes. Chamfer the inside diameter of the top of the pellet discharge tube and insert the tube into the grommet so approximately 1 inch (2.5 cm) protrudes above the grommet. Install the push nut on the tube. Insert the vent assembly into the grommet so the push nut is against the grommet. Install a push nut on the vent pipe at the underside of the vent assembly to lock the vent in place.

---

**Caution:** All vents must be above flood plain or high water level to prevent surface water from entering and contaminating well.

---

7. Lower the pellet discharge tube into the well. Before clamping the cover to the casing, complete the electrical connections required for the chlorinator. See section III, Electrical Installation. Upon Completion of the electrical wiring, complete steps 8 through 10.
8. Place the well cover on the well casing and tighten the clamping screws.
9. Drop a chlorine pellet down the tube. Listen to it hit the water. This will indicate that preceding steps have been performed correctly.

---

**Caution:** Do not operate the LAND-O-MATIC if the pellet cannot be heard hitting the water.

---

10. Install the clear plastic pellet tube supplied with the LAND-O-MATIC Chlorinator (Figure 4). Shorten the tube as necessary so there are no kinks or obstructions to interfere with the falling of the chlorine pellets. Install hose clamps at both ends of the clear plastic tube.

Figure 5

B. For wells equipped with a vented well cap:

beginning of section 9.

16.5(l)6.5(l) 7.9(t)15.1(h)4.4(e)2

---

**Caution:** Do not use the capacitor start wire as a chlorinator connection as both chlorinator and well pump motors will be damaged.

---

2. Select the wire schematic diagram to be followed from Figures 8, 9, 10, or 11 and circle for future reference.
- 

**Caution:** Turn off electrical power to the well pump and the pressure switch before wiring.

---

3. Install "FLEXTITE" type electrical connectors and conduit between the LAND-O-MATIC and the electrical connection point (well cap, pressure switch, etc.). All electrical wiring must be watertight.

**Note:** The LAND-O-MATIC is provided with a 1/2-inch NPT connector.

4. Remove the electrical box cover from the LAND-O-MATIC and connect the proper color coded 20 gauge (or heavier) wire to the appropriate wires on the LAND-O-MATIC (Figures 8, 9, 10, or 11). Use wire nuts provided. Be sure to install a ground wire.
  5. Run connecting wires through the conduit and connect the other end of the wires to selected connection point using approved methods.
  6. Replace the electrical box cover on the LAND-O-MATIC, making sure O-ring is properly placed.
  7. Install the well cover if not already in place and complete steps 8 through 10 in Section II A.
  8. Turn on the electrical power to the pressure switch and the well pump.
- 

**Caution:** Chlorinator requires grounding approved by the National Electrical Code.

---

**Note:** Where the pump is controlled by a pressure switch (Figures 9, 10, and 11) a pressure switch with "low pressure cut-off" feature (Square D Model FSG Form M4 or equal) is recommended.

**For installation of the LAND-O-MATIC LP-3000 in the State of Wisconsin:**

Drop tube and vent installation to comply with the State of Wisconsin/Department of Natural Resources well code.

Instructions

1. To comply with well code Chapter NR112, Wisconsin Administrative Code, an approved watertight, vermin-proof well cap must be installed. Pentair Water recommends the following well caps:

Well Casing Size	Model Number*
5 inches	952814
6 inches	952816

\*Manufacturer:

Maas Midwest Mfg.  
11283 Dundee Road  
P.O. Box 547  
Huntley, IL 60142  
(847) 669-5135

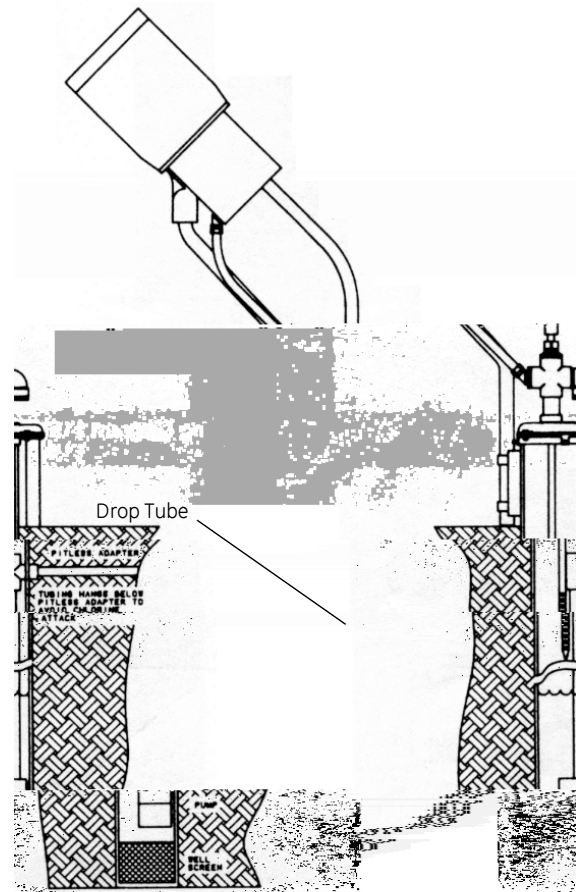

Figure 6

2. The drop tube should extend below the pitless adapter, Figure 6.
3. The drop tube should have a minimum of 40 vent holes.
4. The end of the drop tube should have a tapered end in order to promote moisture release and prevent clogging of the drop tube with pellets.

5. The drop tube should be constructed from 3/4 inch CFG CPVC 4120 SPR 11, ASTM D2846, NSF approved.
6. Use Pentair Water well vent assembly No. 1032507. This assembly will provide an additional 0.75 square inches of vent surface area and provision for electrical connections.
7. The chlorinator pellets must fall freely from the chlorinator into the water in the well casing without interference from pitless adapters, cable guards, torque stops, excess electrical wire or related pump fittings. Chlorine pellets in contact with metal parts will cause severe corrosion.

**Note:** The LAND-O-MATIC should not be installed on bacteriologically unsafe water supplies.

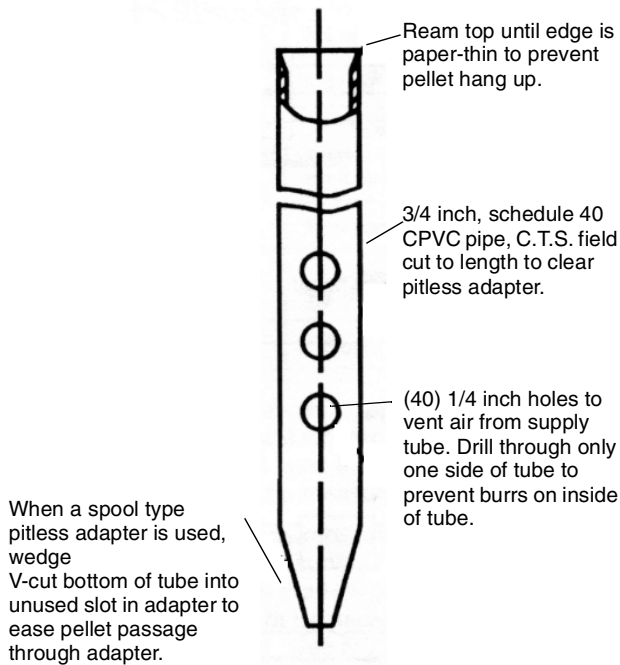

Figure 7

### 3-Wire Submersible Pump Connection 115 Volt or 230 Volt

**Caution:** Submersible pumps have one high voltage capacitor start wire (normally red) and two running wires. Connecting the chlorinator to the high voltage capacitor wire WILL CAUSE CHLORINATOR MOTOR FAILURE and possibly damage the submersible pump motor. Motor failures caused by incorrect wiring are NOT covered by Warranty.

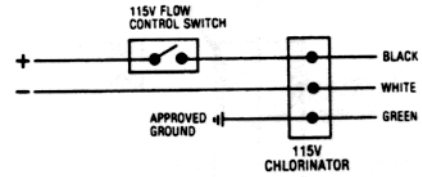

Figure 8 Wiring Diagram 115 V Chlorinator Flow Switch Operated

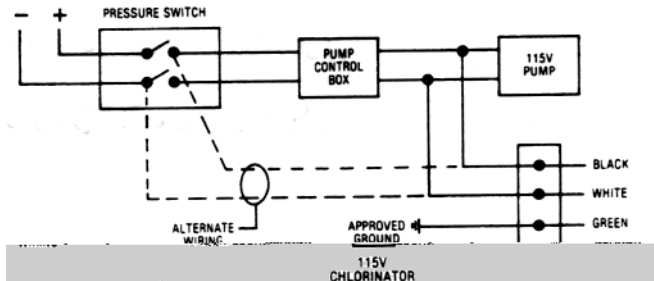

Figure 9 Wiring Diagram, 115 V Chlorinator, 115 V Well Pump

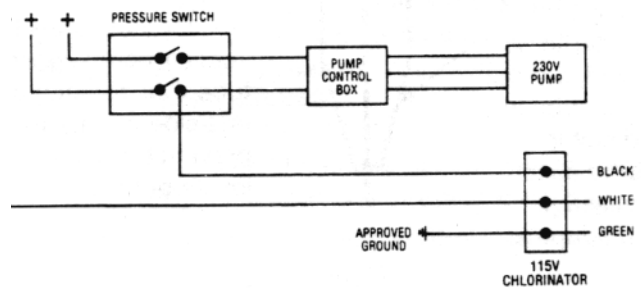

Figure 10 Wiring Diagram 115 V Chlorinator, 230 V Well Pump

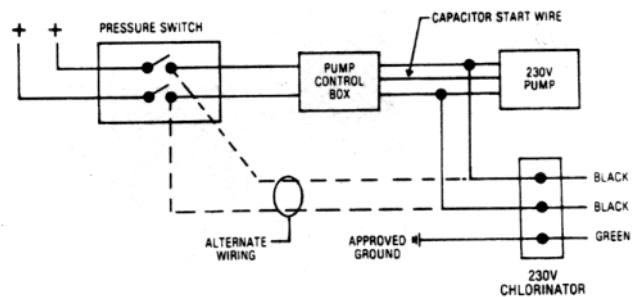

Figure 11 Wiring Diagram 230 V Chlorinator, 230 V Well Pump

## IV. System Checkout

Before adding pellets, run water until the well pump runs. The chlorinator pilot light should be on (Figure 12) and the pellet plate (Figure 13) should rotate with a stop and start motion while the water pump runs.

If the chlorinator pilot light does not go on, check the electrical connections.

If the pilot light is on and the pellet plate does not rotate, check the pellet feed index knob setting. Set feed index knob at #5 or higher.

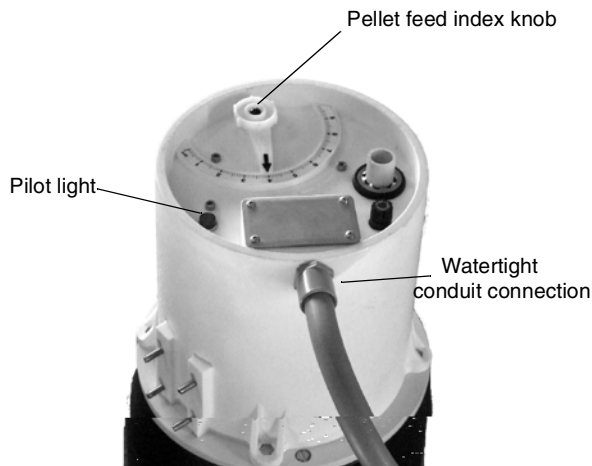

Figure 12

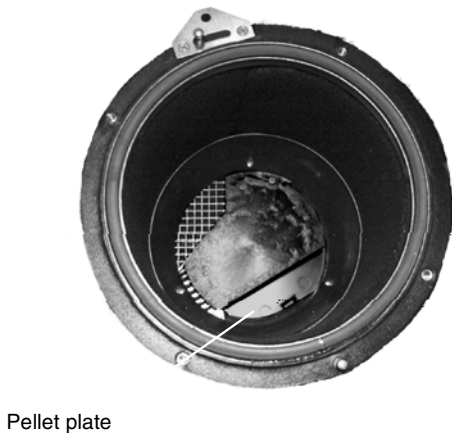

Figure 13

## V. Feed Rate

A. The chlorine feed rate required will vary based on two factors:

1. The “chlorine demand” of the well water.
2. The flow rate at which water is pumped from the well.

**Note:** The chlorinator must be adjusted to deliver between 0.4 and 0.8 ppm of chlorine for water used for human consumption and up to 3 ppm for livestock water system protection.

B. Estimating the chlorine demand:

The following guide can be used to estimate the amount of chlorine required and to determine the initial number of pellet plugs to be removed, see Table 2. Be aware that this is only a means to estimate usage and will vary depending on your particular application.

1. Use guide to estimate the dosage rate for the condition you wish to treat. If more than one condition exists, add up individual dosage rates to obtain total dosage rate.

Chlorination Treatment For:	Typical Chlorine Dosage Rates:
Algae	3-5 ppm chlorine
Bacteria	3-5 ppm chlorine
Hydrogen sulphide (H <sub>2</sub> S): Taste and odor control	1 ppm H <sub>2</sub> S requires 2 ppm Chlorine, see Note 1.
Destruction	1 ppm H <sub>2</sub> S requires 8.4 ppm Chlorine, see Note 1.
Iron bacteria	1-10 ppm chlorine, see Note 2
Iron precipitation	1 ppm Fe requires 0.64 ppm chlorine
Manganese precipitation	1 ppm Mn requires 1.3 ppm ppm chlorine
Odor	1-3 ppm chlorine

**Note:** (1) Feeding 2 ppm of chlorine for each part of H<sub>2</sub>S will remove taste and control odor. It will take at least 8.4 ppm of chlorine before a residual will be measured.

Iron - or sulfate-reducing bacteria can cause H<sub>2</sub>S in water supply. Eliminating the bacteria will eliminate the H<sub>2</sub>S odor, and direct treatment of H<sub>2</sub>S will not be necessary once the bacteria are removed. See NOTE (2).

**Note:** (2) High quantities of chlorine are required to react with and eliminate growth of slime in the well caused by bacteria. Once removed, much lower settings can be used to keep the bacteria from becoming reestablished in the water system.

2. Once the required chlorine dosage rate has been estimated, use the PELLET PLUG CHART, Table 2 to estimate the total chlorine usage and the number of pellet plugs to be removed to obtain the desired dosage rate.
- C. Determine actual pumping rate in GPM from the pump specification sheet, pump installer or by test.
- D. For the calculated chlorine dosage rate and the actual pumping rate, use PELLET PLUG CHART to determine the number of pellet plugs to be

removed. The LAND-O-MATIC is shipped with one plug removed.

- E. Remove appropriate number plugs determined in steps C, D, and E. Remove alternate plugs with the plug key provided (Figure 14). Do not use a screwdriver. Pellet plate can be rotated counterclockwise by hand to expose pellet plugs.

Remove plugs as determined

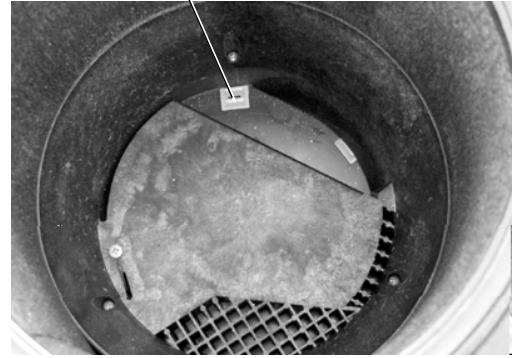

Figure 14

**Table-2 Pellet Plug Chart —Number of Pellet Plugs Removed**

Estimated Chlorine Usage		Chlorine Dosage Rate PPM	Gallons Per Minute												
Gal Water Treated Per Lb. of Chlorine	Gal Water Treated Per Pellet		10	15	20	30	40	50	75	100	125	150	200	400	600
84,000	185	1.0	1	1	1	1	1	1	1	1	1	1	2	3	4
42,000	92	2.0	1	1	1	1	1	1	1	2	2	2	3	5	6
28,000	61	3.0	1	1	1	1	1	1	2	2	2	3	4	6	
21,000	46	4.0	1	1	1	1	1	2	2	3	3	3	5		
17,000	37	5.0	1	1	1	1	2	2	2	3	4	4	6		
14,000	31	6.0	1	1	1	1	2	2	3	4	5	5	6		
12,000	26	7.0	1	1	1	2	2	2	3	4	5	6			
10,000	23	8.0	1	1	1	2	2	3	4	5	5	6			
9,100	20	9.0	1	1	2	2	3	3	4	5	6				
8,100	18	10.0	1	1	2	2	3	3	4	6	6				
6,800	15	12.0	1	2	2	3	3	4	5	6					
5,400	12	15.0	1	2	2	3	4	5	6						
4,500	10	18.0	1	2	3	4	5	6							
4,000	9	20.0	2	2	3	4	5	6							
3,200	7	25.0	2	3	3	5	6						All Pellet Plugs Removed		
2,700	6	30.0	2	3	4	6									
2,300	5	40.0	3	4	5	6									
1,800	4	50.0	3	4	6										
1,000	2	75.0	6												



## VI. Operation

A. The LAND-O-MATIC controls are located beneath the unit for weather protection.

- **Pellet Food Index Knob**

Adjusts pellet feed rate. 10 is the maximum setting. To change pellet feed rate, pull index knob down and rotate. The higher the number setting the more chlorine is fed.

- **Fuse**

All 115 volt models are fused to prevent damage to the LAND-O-MATIC if accidentally connected to a 230 volt circuit.

- **Pilot Light**

Indicates when the LAND-O-MATIC is energized and working.

B. To add pellets, remove the four cover screws. Rotate the cover counterclockwise approximately 1 inch and lift off. Add pellets to pellet container (Figure 15), reinstall cover with the lock rings together and tighten the four container cover screws securely (Figure 16). Be sure cover gasket is intact and sealing properly. a maximum of two months' supply of pellets should be added at one time. Use only pellets manufactured by Pentair Water.

**Note:** It is important to keep the LAND-O-MATIC pellet container cover and pellet shipping container cover TIGHTLY CLOSED. Chlorine absorbs moisture from the air. Damp pellets are not suitable for use in the LAND-O-MATIC. The limited warranty will not cover damage due to moisture-softened pellets used in the LAND-O-MATIC.

C. To prevent children and unauthorized persons from opening the pellet container, a padlock should be installed (Figure 16).

D. Use the pellet feed index knob (Figure 12) to make adjustments for individual wells. Start system at setting 5. Once each day, check water for proper chlorine residual with the test kit provided. To decrease chlorine content, pull out and move index knob to a lower setting. To increase chlorine content, move index knob to a higher setting.

E. If chlorine residual is too low with pellet feed index knob set at 10, the highest feed rate, remove additional pellet plate plugs (see Section V, Step E) and repeat procedure.

F. Unchlorinated water can carry bacteria. check the chlorine content of the well water every day and adjust the chlorine feed rate accordingly.



Figure 15



Figure 16

## VII. Operation Requirements

Your LAND-O-MATIC Dry Pellet Chlorinator is the most reliable chlorination system available today. However, in order to realize the continued benefits of chlorinated water, the following procedures must be followed by the owner.

A. **TEST WATER DAILY** for chlorine residual using the test kit provided. Adjust chlorinator feed rate to maintain the residual at 0.4 to 0.8 ppm for human consumption and 1 to 3 ppm for livestock water.

B. **MAINTAIN A SUPPLY OF CHLORINE PELLETS.** The LAND-O-MATIC's pellet container must be kept supplied with pellets meeting for specifications required for this machine, Use only Pentair Water dry chlorine pellets, available from your LAND-O-MATIC dealer.

C. **WORK SAFELY.** Chlorine is a strong oxidizer and requires careful handling. Handle chlorine pellets as instructed on page 12 of this manual. Read the

label on the pellet container. Keep children away from the chlorinator and the stored pellets.

- D. KEEP PELLETS DRY. The chlorinator pellet container must be kept tightly closed using the four screws provided, to prevent moisture absorption. Chlorinator damage due to damp pellets is not covered by the limited warranty.
- E. LAND-O-MATIC chlorine pellets are shipped in containers designed to be child resistant and air tight. Securely replace cover on opened chlorine pellet container.

## VIII. Plumbing Requirements

### A. Contact Time

For effective bacteria kill and iron precipitation, chlorine at prescribed levels must be in contact with the water for 20 minutes. By adding chlorine to the well, the LAND-O-MATIC Dry Pellet Chlorinator has the benefit of using the well casing, pump, riser and lateral pipes for added retention time. If water demand requires nearly continuous running of the pump, a properly-sized retention tank must be initialized to assure proper retention times. Figure 17 shows proper location of the retention tank in the system.

### B. Carbon Filters

To provide effective filtration of precipitated iron, manganese and excess chlorine, install a carbon filter in the household water supply line (Figure 17). Chlorine-free drinking water can be obtained by

installing point-of-use carbon filter. Livestock water should not be passed through a carbon filter.

---

**Caution:** Carbon filters remove chlorine taste and odor. To insure that the chlorinator system is functioning properly and that proper protection is being maintained, a daily chlorine test must be taken ahead of the carbon filter.

---

## IX. Removing and Reinstalling the Pellet Container Assembly

Remove the three screws which fasten the pellet container to the motor housing cover (Figure 18).

Pull the pellet container away from the motor housing assembly.

To reassemble the pellet container to the drive unit, see Figure 18. Rotate the clutch so that the clutch springs line up with the pellet tube extension.

Rotate the pellet plate square drive end so that the flats line up with the pellet tube recess. Engage the pellet tube recess on the pellet container assembly with the pellet tube extension on the drive unit. Push down to engage the pellet plate square drive end with the clutch.

If the pellet plate does not engage with the clutch, rotate the pellet plate slightly until engagement can be made.

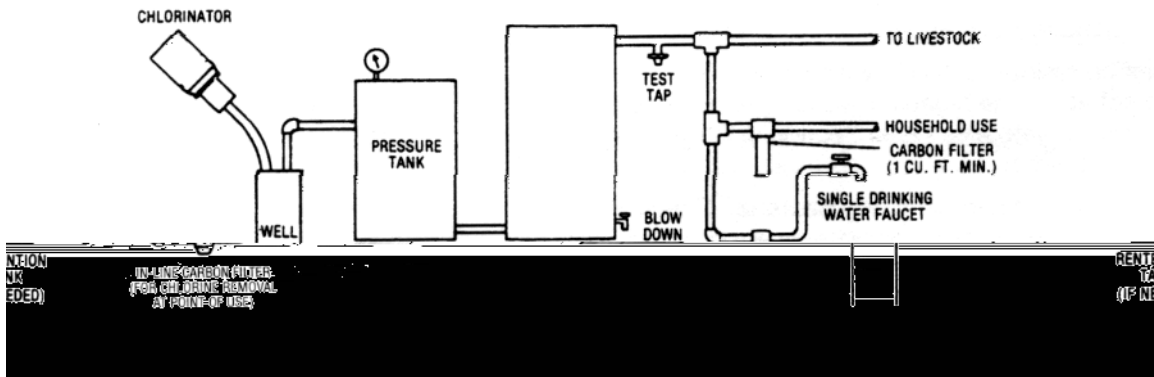

Figure 17

## Caution in Handling Chlorine:

- Chlorine is a strong oxidant.
- Keep pellet containers tightly closed and child resistant locking devices in place.
- May cause eye damage. Do not get in eyes.
- May produce chemical burns. Avoid contact with skin and clothing.
- May be harmful or fatal if swallowed. Keep pellets out of reach of children.
- Always rinse empty container with water, then destroy.
- Store pellets in a cool, dry place, away from heat, sparks and flame.
- Always keep pellets clean and free from any dirt, grease, or other foreign materials.
- Always use a clean plastic container or scoop to handle pellets. NEVER BARE HANDS OR CLOTH GLOVES. Clean rubber gloves can be used. NEVER INHALE DUST OR FUMES when handling chlorine pellets.

**Antidotes:**

**External** - Wash with water for at least 15 minutes.

**For eyes** - Get prompt medical attention.

**Internal** - Drink quantities of milk, water or egg whites.  
**CALL A PHYSICIAN IMMEDIATELY!**

**Danger to Animals and Birds:**

In certain types of vaccinations and medications, it may be necessary to remove the chlorine from the water. Consult your veterinarian as to when it is necessary to eliminate chlorine. Use a carbon filter to remove chlorine during these periods.

**Note:** Changing water conditions by adding chlorine or removing iron bacteria, hydrogen sulfide, softening,

etc. will change the taste of the water. Animals and birds may reduce their normal water consumption until they become accustomed to the new taste of the water. This temporary reduction in water consumption may temporarily affect the animals production. To minimize this effect, start feeding chlorine at a very low rate and increase to the recommended levels over several weeks time.

**Chlorine Identification:**

Calcium Hypochlorite Mixture  
#UN 2880, EPA No. 5051001.

Pentair Water reserves the right to make improvements to this product which might not be reflected in this owner's manual.



Figure 18

# Casing Mount Replacement Parts

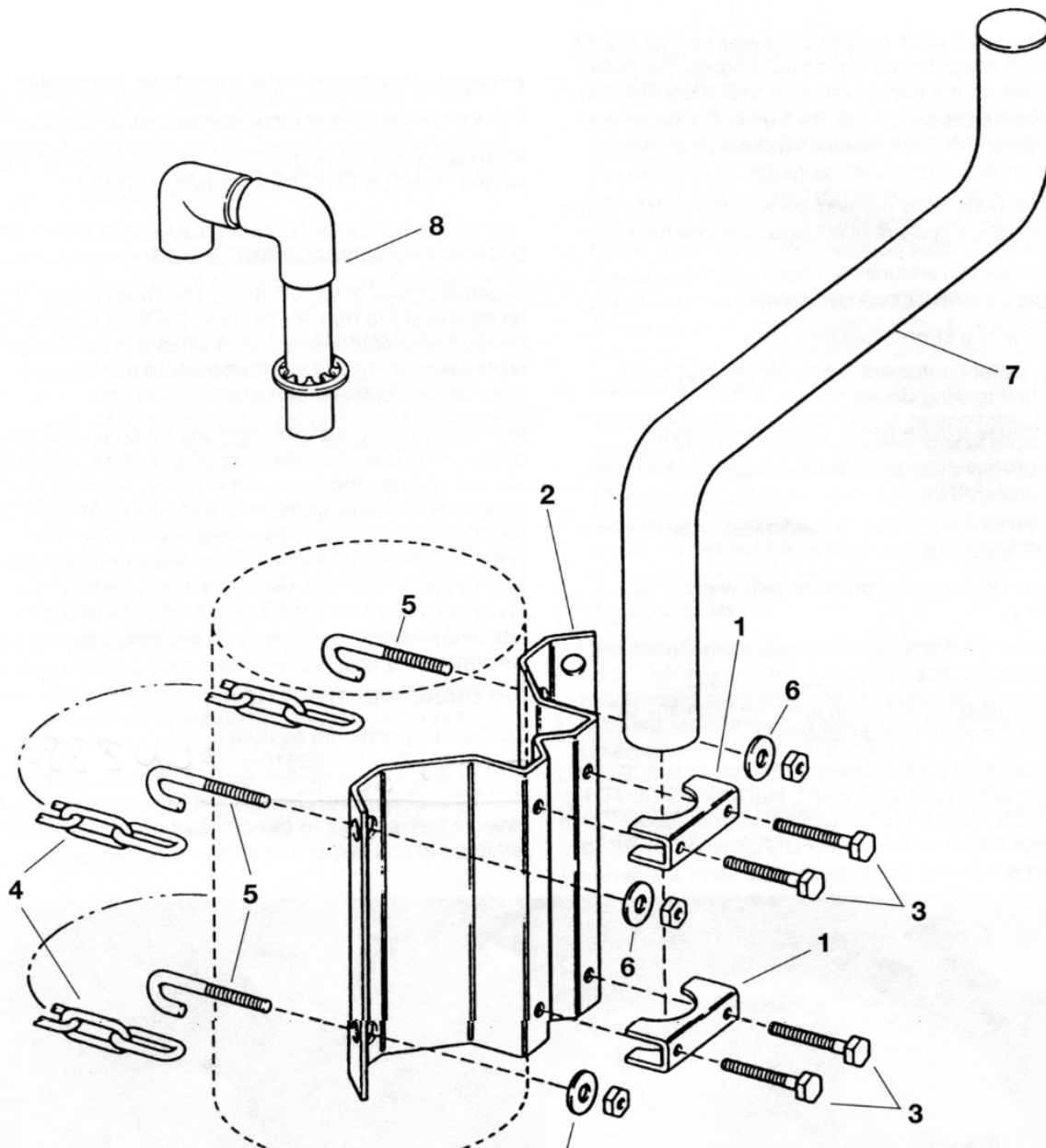

Item	Part No.	Description	Item	Part No.	Description
1	1031038	Clamp	6	1006535	Washer 5/16, Flat
2	1032968	Bracket, Casing Mount	7	1032937	Support Tube
3	1005358	Cap Screw 5/16-18 x 2	8	1032940	Well Vent Assembly, Std.
4	1004020	Chain	*	1032507	Well Vent Assembly, Vermin Proof
5	1004124	J-Bolt with Nut			

\*Not Shown

# Pellet Container Assembly

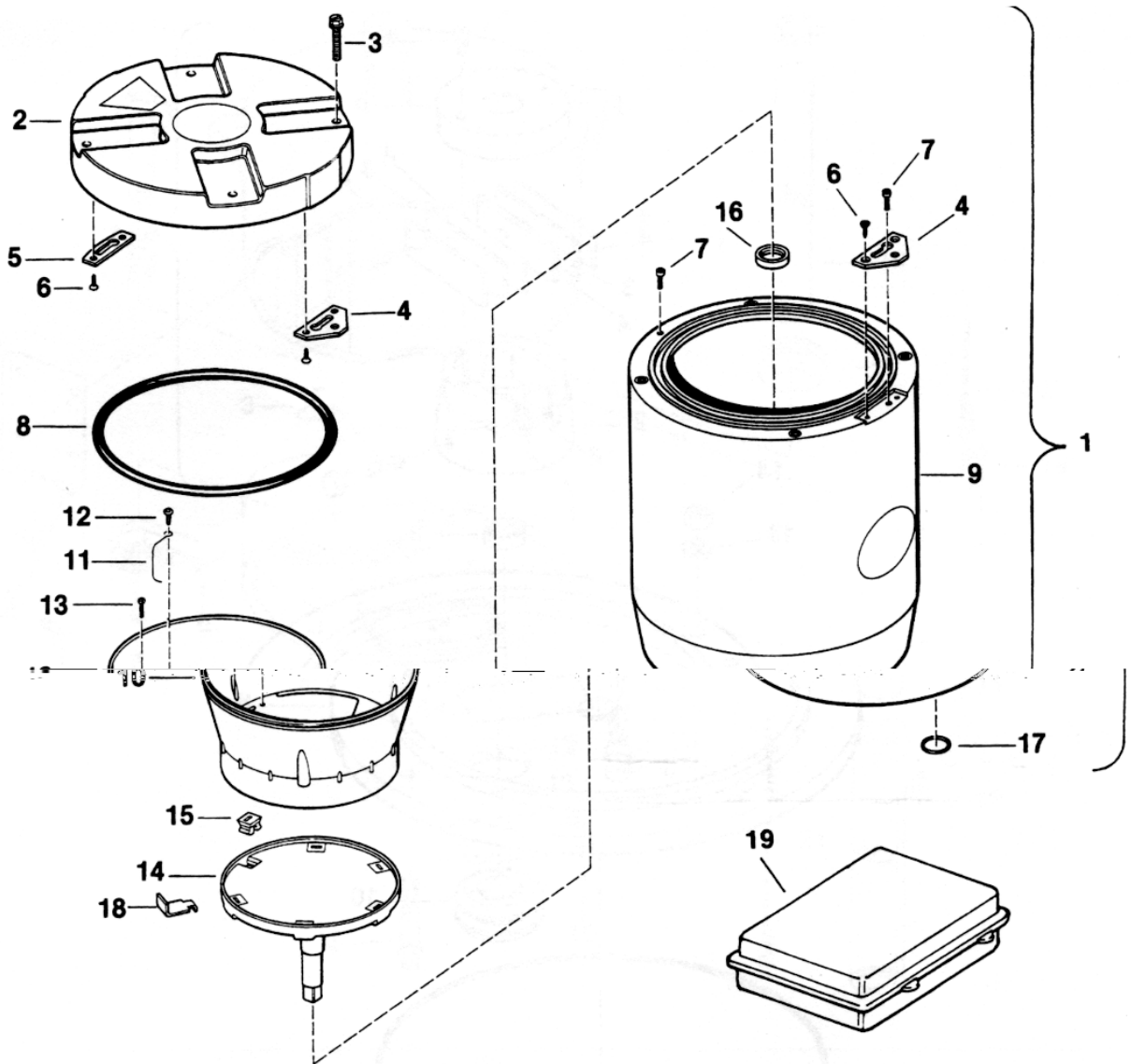

Item	Part No.	Description	Item	Part No.	Description
1		Pellet Container Assembly Complete (Incl. items 2 thru 17):	10	1032423	Funnel
	1032487	15 lb. Lockable	11	1031355	Spring, Funnel
2	1032506	Cover, Pellet Container	12	1005971	Screw, #8-18 x 1/2 Type 25
3	1005696	Screw, 1/4-20 x 1-1/2	13	1006040	Screw 6-32 x 5/8
4	1031032	Plate, Locking	14	1032928	Plate, Pellet
5	1031034	Plate, Locking	15	1031716	Plug, Pellet Plate
6	1005811	Screw, #8-18 x 5/8 Type AB	16	1010804	Seal, Pellet Plate
7	1005520	Screw, #10-24 x 5/8 Fil. HD.	17	1010125	O-Ring, Discharge Tube
8	1001619	Gasket, Pellet Container Cover	18	1031025	Tool, Plug Removal
9		Container, Pellet:	19	1001557	Chlorine Test Kit
	1032504	15 lb. Capacity			

# Replacement Parts

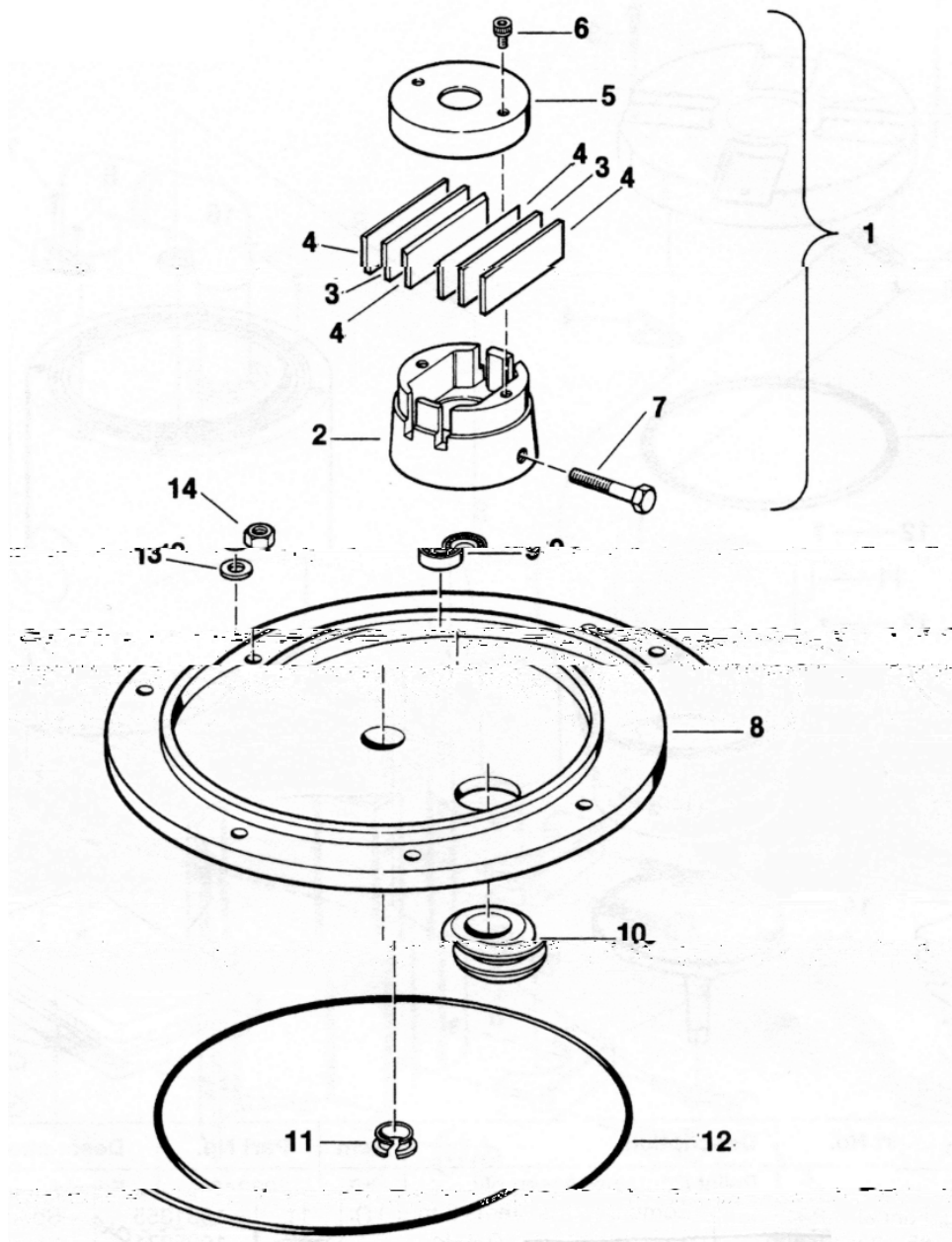

Item	Part No.	Description	Item	Part No.	Description
1	1032914	Clutch Assembly (2 thru 8)	8	1032931	Motor Housing Cover Assembly
2	1031715	Clutch Hub	9	1010801	Output Shaft Seal
3	1031016	Clutch Spring	10	1010860	Discharge Tube Grommet
4	1031024	Clutch Spring Protector	11	1013551	Pilot Bearing
5	1031708	Clutch Cover	12	1001618	Cover Gasket
6	1006251	Screw 10-32 x 1/4	13	1006474	Washer 1/4 Flat
7	1005354	Screw 1/4-20 x 1-1/2	14	1005193	Nut 1/4-20

# Replacement Parts

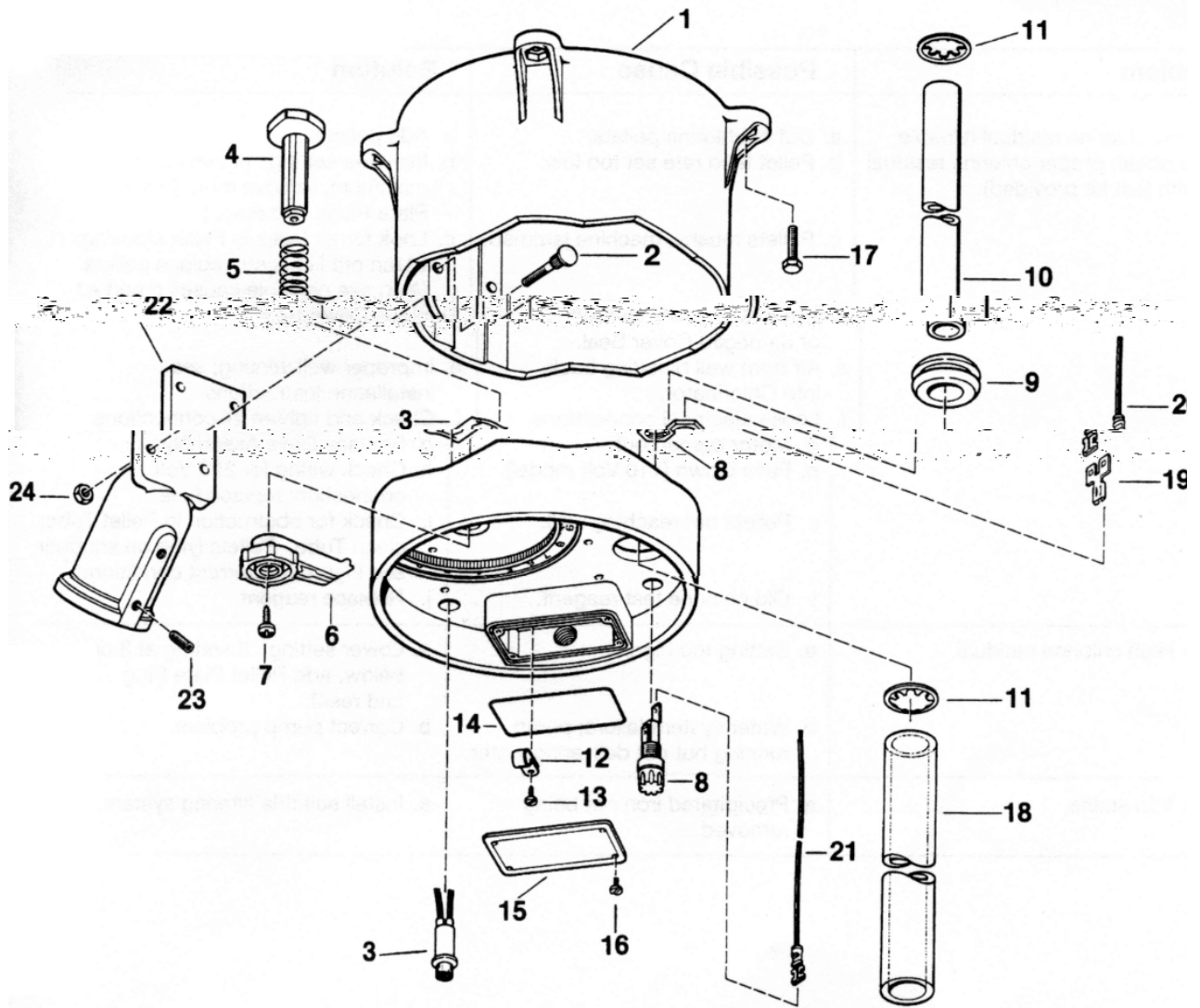

Item	Part No.	Description	Item	Part No.	Description
1	1032446	Motor Housing Assembly:	10	1001344	Discharge Tube
	1032447	230 Volt	11	1004265	Push Nut
		115 Volt	12	1004021	Cable Clamp
2	1005052	Ribbed Neck Bolt	13	1005916	Screw, #6 x 1/2 Type A
3		Pilot Light w/Push Nut:	14	1010134	Cover Gasket
	1007800	230 Volt	15	1031013	Electrical Box Cover
	1007801	115 Volt	16	1005970	Screw, #6 x 3/8 Type 25
4	1032219	Cam	17	1005353	Screw, 1/2-40 x 1
5	1030490	Cam Spring	18	1001617	Clear Plastic Tube
6	1032218	Selector Knob	19	1008359	Terminal Adaptor 115V Only
7	1005954	Screw, #10-16 x 3/4 Type BT	20	1033115	Wire Assembly
8	1007720	Fuse Holder with Nut	21	1033752	Wire Assembly
		Fuse - Refer to Decal at Fuse	22	1032225	Mounting Bracket
		Holder for Amp Rating	23	1006202	Set Screw, 5/16-18 x 3/4
9	1010860	Discharge Tube Grommet	24	1005193	Hex Nut, 1/4-20

# Troubleshooting

Problem	Possible Cause	Solution
<p>1. Low chlorine residual (Unable to obtain proper chlorine residual with test kit provided.)</p>	<ul style="list-style-type: none"> <li>a. Out of chlorine pellets.</li> <li>b. Pellet feed rate set too low.</li> <li>c. Pellets mush; machine jammed.</li> <li>d. Cover of Chlorinator left off or damaged Cover Seal.</li> <li>e. Air from well bleeding back into Chlorinator.</li> <li>f. Loose electrical connections.</li> <li>g. Motor burned out.</li> <li>h. Fuse blown (110 Volt model).</li> <li>i. Pellets not reaching well.</li> <li>j. Old chlorine test reagent.</li> </ul>	<ul style="list-style-type: none"> <li>a. Add pellets.</li> <li>b. Increase setting. (If setting at maximum, remove more Pellet Plate Plugs and reset).</li> <li>c. Look for air leaks in Pellet Housing: Clean out Housing, replace pellets (Also see possible causes of d and e).</li> <li>d. Replace Cover Seal.</li> <li>e. Improper well venting: see installation instructions.</li> <li>f. Check and tighten all connections.</li> <li>g. Replace Drive Assembly.</li> <li>h. Check wiring for 220 Volt connection; replace fuse.</li> <li>i. Check for obstruction in Pellet Tube; Clean Tube. Pellets lying on snubber, see Figure 5. Correct condition.</li> <li>j. Replace reagent.</li> </ul>
<p>2. High chlorine residual.</p>	<ul style="list-style-type: none"> <li>a. Setting too high.</li> <li>b. Water system failure; pump running but not delivering water.</li> </ul>	<ul style="list-style-type: none"> <li>a. Lower setting. If setting at 3 or below, add Pellet Plate Plug and reset.</li> <li>b. Correct pump problem.</li> </ul>
<p>3. Iron stains.</p>	<ul style="list-style-type: none"> <li>a. Precipitated iron not being removed.</li> </ul>	<ul style="list-style-type: none"> <li>a. Install suitable filtering system.</li> </ul>



---

## ***Important Notice***

---

The level of contaminants in your raw water fluctuates constantly. therefore, use your test kit to check for a proper chlorine residual (between 0.4 ppm and 2 ppm) at least once a week.

In order to obtain complete satisfaction from your new LAND-O-MATIC Chlorination System, it is extremely important that you become familiar with the operation of the equipment.

Although the LAND-O-MATIC is virtually maintenance-free, it will not perform to your expectations if neglected or improperly used.

Since the LAND-O-MATIC pellet dispenser is the “heart” of your chlorination system, a proper understanding of how it operates is essential. Please study the owner’s manual for details on how to adjust it, so you have a chlorine residual of between 0.4 ppm and 2 ppm in the unfiltered water at all times. Excess chlorine residual could signal chlorine dissolving problems in the well and requires immediate attention.

In some cases, it may take several weeks or more to clean out heavy deposits of rust, sludge and bacterial slime which have accumulated in your well, pipes and pressure tank. Under these conditions, a fairly high dosage of chlorine is required in order to obtain a residual. After the initial “clean-out period” however, much less chlorine is needed to maintain the correct residual.

If you experience any problems, please refer to the trouble shooting guide in the owner’s manual. If the problem is not listed, or a component malfunction is indicated, please contact your LAND-O-MATIC chlorination supplier immediately.

Properly operated, your LAND-O-MATIC chlorination System will give you years of trouble-free service, and enable you to enjoy the many benefits of clean, problem free water. We hope you are pleased with the results.





